



SURFACE MOUNT BRIDGE RECTIFIER

DF005S THRU DF10S

Case Style DFS (MDB)

FEATURES

- Glass passivated chip junction
- Ideal for surface mounted applications
- Low leakage
- High forward surge current capability.
- High temperature soldering guaranteed:
260°C/10 seconds at terminals.

MECHANICAL DATA

- Case: Molded plastic body
- Epoxy: UL94V - 0 rate flame retardant.
- Polarity: Molded on body.
- Lead: Plated terminals solderable per MIL - STD - 202E
method 208C
- Weight: 0.04 ounce, 1.0 gram

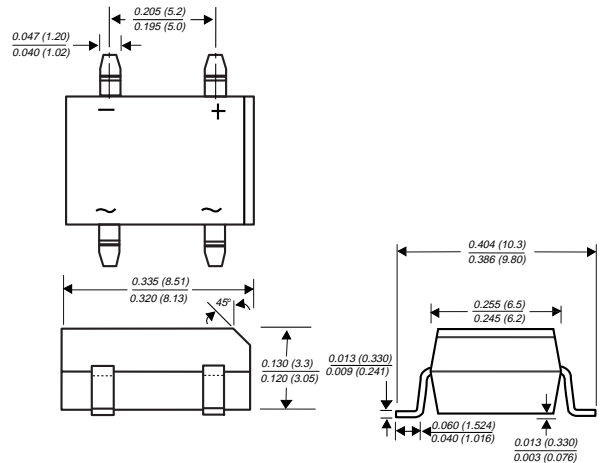

Dimensions in inches and (millimeters)

MAXIMUM RATINGS AND ELECTRICAL CHARACTERISTICS

- Ratings at 25°C ambient temperature unless otherwise specified
- Single phase, half wave, 60Hz, resistive or inductive load.
- For capacitive load derate current by 20%

	SYMBOLS	DF005S	DF01S	DF02S	DF06S	DF06S	DF08S	DF10S	UNITS
Maximum Repetitive Peak Reverse Voltage	V_{RRM}	50	100	200	400	600	800	1000	Volts
Maximum RMS Voltage	V_{RMS}	35	70	140	280	420	560	700	Volts
Maximum DC Blocking Voltage	V_{DC}	50	100	200	400	600	800	1000	Volts
Maximum Average Forward Rectified Output Current, 0.06" (1.5mm) lead length at $T_A = 40^\circ\text{C}$ (Note)	$I_{(AV)}$	1.0							Amp
Peak Forward Surge Current 8.3ms single half sine-wave superimposed on rated load (JEDEC Method)	I_{FSM}	50							Amps
Rating for Fusing ($t < 8.3\text{ms}$)	I^2t	10							A^2s
Maximum Instantaneous Forward Voltage Drop at 1.0A	V_F	1.1							Volts
Maximum DC Reverse Current at rated DC blocking voltage per element	I_R	$T_A = 25^\circ\text{C}$							μA
		$T_A = 125^\circ\text{C}$							mA
Typical Junction Capacitance (Note 1)	C_J	25							pF
Typical Thermal Resistane (Note 2)	$R_{\theta JA}$	40							$^\circ\text{C}/\text{w}$
Operating and Storage Temperature Range	T_J, T_{STG}	(-65 to +150)							$^\circ\text{C}$

NOTES:

1. Measured at 1.0 MHz and applied average voltage of 4.0 volts.
2. Unit mounted on P.C.B. with 0.51" X 0.51" (13 X 13mm) copper pads.

RATINGS AND CHARACTERISTICS CURVES DF005S THRU DF10S

FIG. 1 - DERATING CURVE OUTPUT RECTIFIED CURRENT

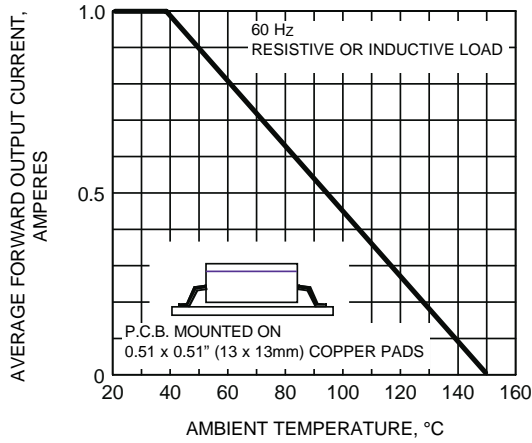

FIG. 2 - MAXIMUM NON-REPETITIVE PEAK FORWARD SURGE CURRENT PER LEG

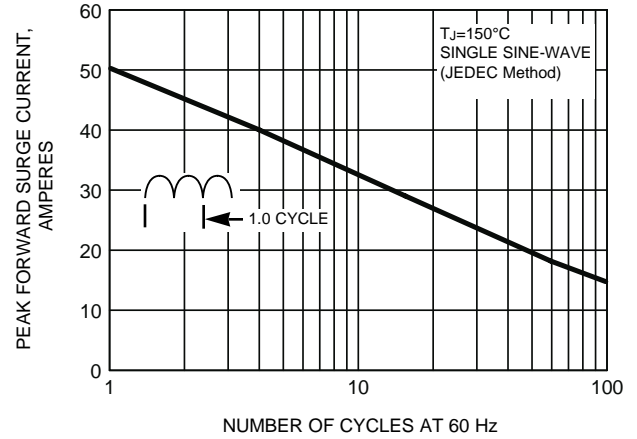

FIG. 3 - TYPICAL FORWARD CHARACTERISTICS PER LEG

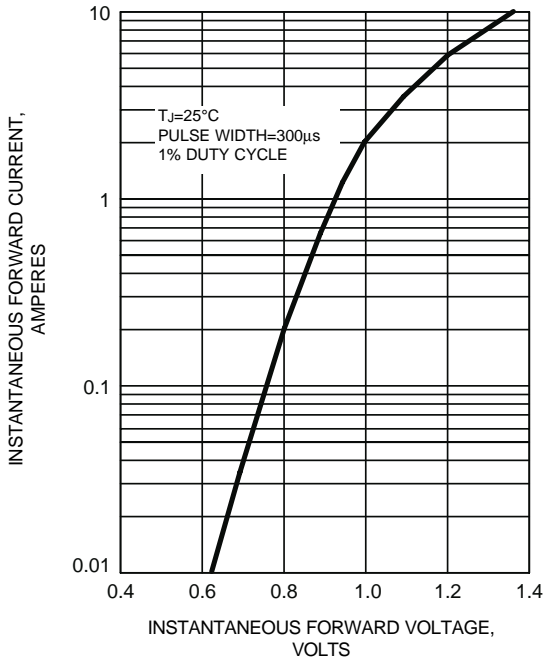

FIG. 4 - TYPICAL REVERSE LEAKAGE CHARACTERISTICS PER LEG

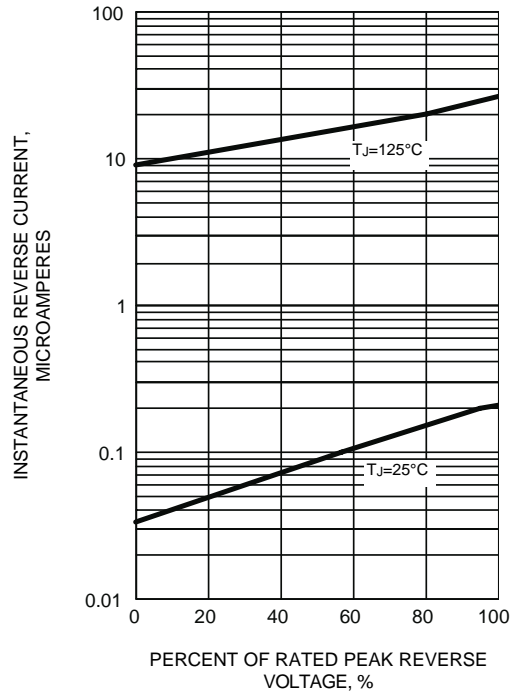

FIG. 5 - TYPICAL JUNCTION CAPACITANCE

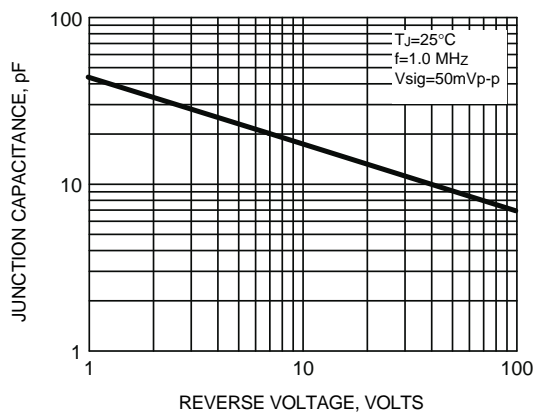

FIG. 6 - TYPICAL TRANSIENT THERMAL IMPEDANCE

